

**No. 3-RT - RISER RING - 1 1/4"**

WT. 15 lbs.

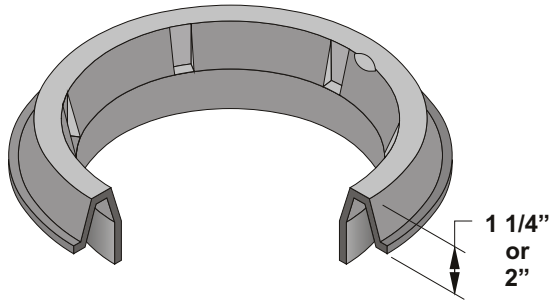

**No. 3-RT - EXTENSION - 6"**

WT. 13 lbs.

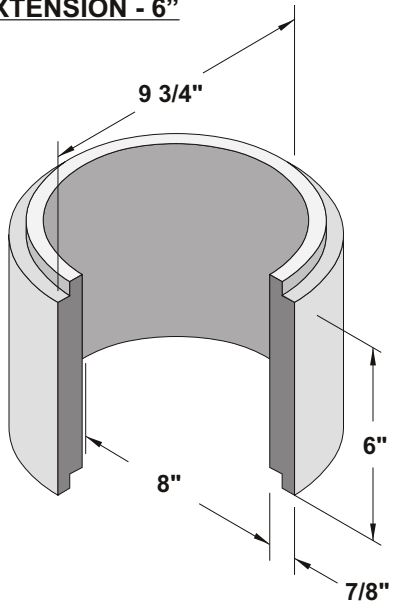

**No. 3-RT - EXTENSION - 12"**

WT. 23 lbs.

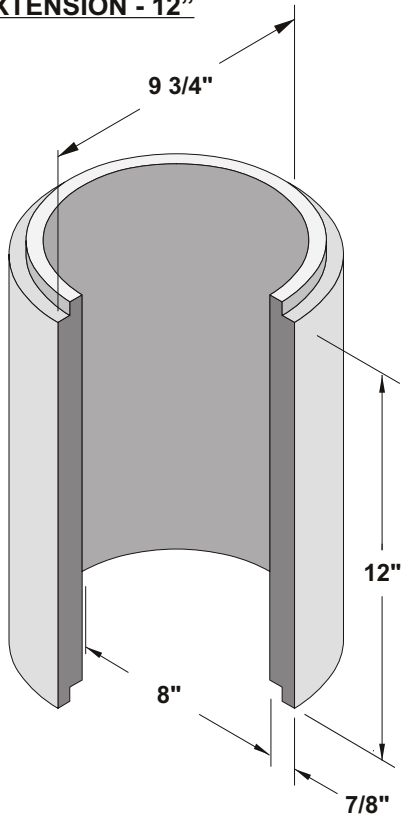

**No. 3-RT-CI COVER**

WT. 12 lbs.

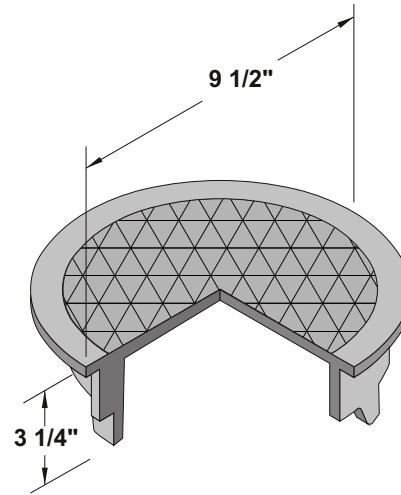

**No. 3-RT - BODY**

WT. 54 lbs.

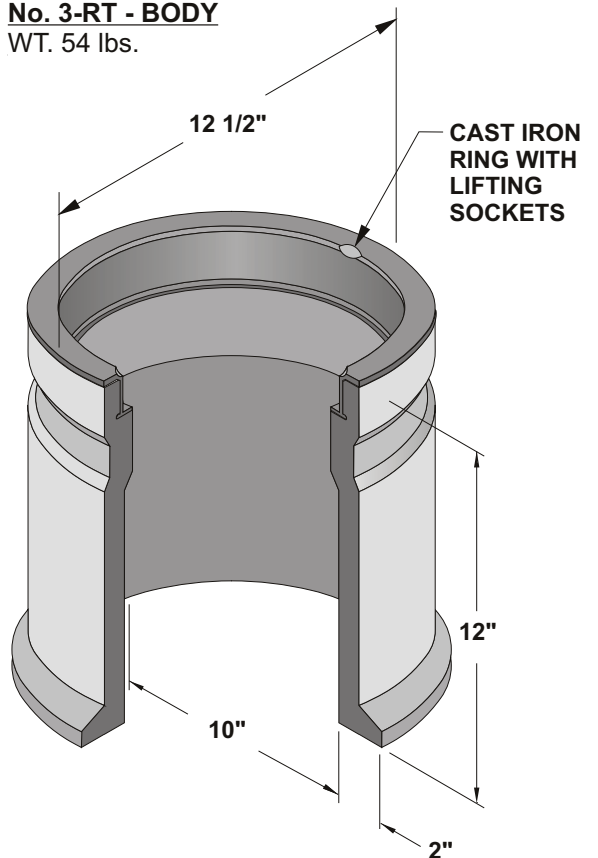

10" Dia. x 12"  
TRAFFIC VALVE BOX

ORG. DWG. DATE  
01-11-96

REV. DWG. DATE  
08-17-00



**3-RT**