

# Process Vessel Reference Electrode

The **Model FE** Process Vessel Reference Electrode is designed to operate in environments where ordinary reference electrodes cannot survive. These include elevated temperatures, high pressures and/or contaminated electrolytes. This is a two-piece unit consisting of a bridge which is permanently installed at each location where potential readings are desired and a separate reference electrode. Because the reference electrode is a separate piece, it is isolated from the aggressive environment which substantially increases its service life. The reference electrode can also be removed for calibration or service without affecting the integrity of the vessel.



The **Model FE10** bridge has a 316L stainless steel nipple which threads into a 1 in. NPT hole. Variations of this are available which thread into a 3/4 inch NPT (**Model FE7**) or a 1/2 inch NPT (**Model FE5**) tapped hole. All three variations have a 1 inch NPT thread on the termination end. Other nipple alloys are available on special order. Bridges can be ordered with extensions ranging from 1 inch (2.5 cm) up to 24 inches (60 cm). Ratings on the bridge are 210°F (98°C) and 150 psi (1 MPa) or 300 psi (2 MPa).

For intermittent readings, a smooth end reference electrode is simply pressed into the bridge. In this case, a single reference can be used with several bridges. When continuous readings are required, a thread end reference electrode is screwed into the bridge. Reference elements available with this product are gelled copper/copper sulfate or gelled silver/silver chloride.

In less demanding environments, our single piece through wall reference electrodes (Models FH or FS) may be suitable.

## **electrochemical devices, inc.**

**Web site:** [www.edi-cp.com](http://www.edi-cp.com)      **Email:** [info@edi-cp.com](mailto:info@edi-cp.com)

**Tel:** 617-484-9085

**Fax:** 617-484-3923

**Address:** P.O. Box 31; Albion, RI 02802-0031

*F Series  
Through-Wall  
Reference  
Electrodes*



**Model FE10 (formerly Model FE)**  
 1 in. NPT x 1 in. NPT nipple

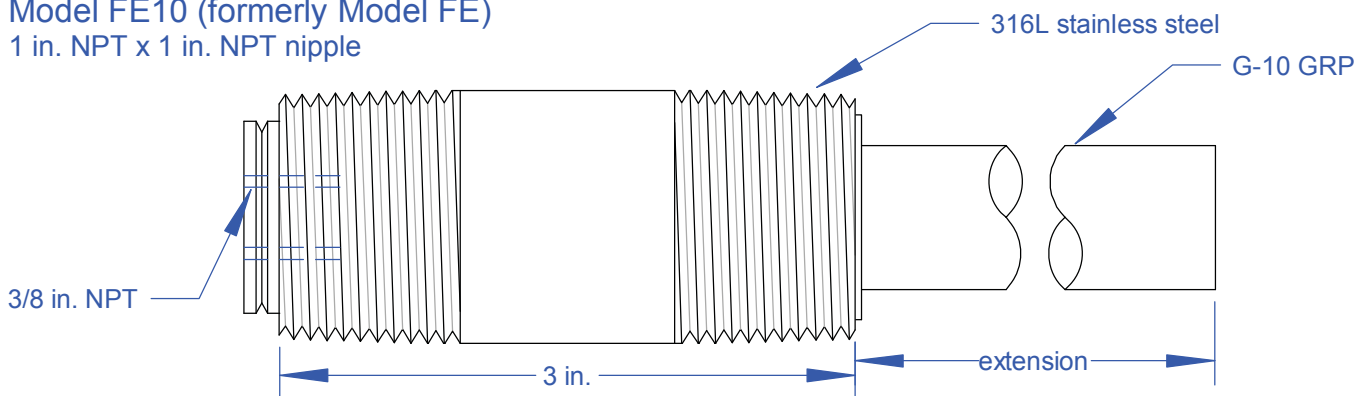

**Model FE7 (formerly Model FX09A)**  
 1 in. NPT x 3/4 in. NPT nipple

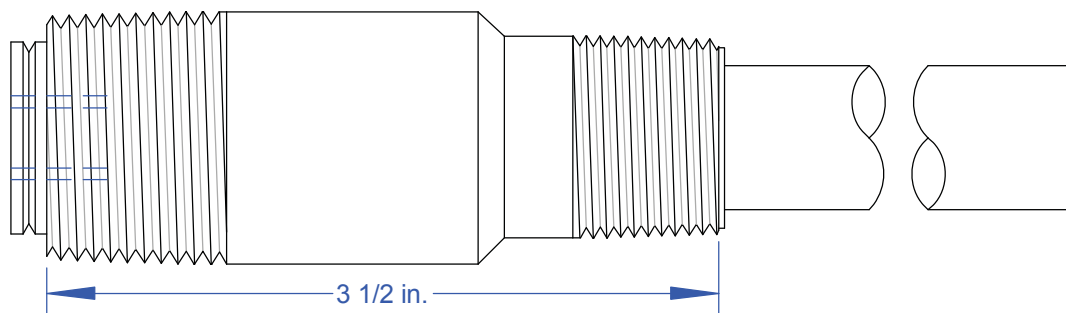

**Model FE5 (formerly Model FX09B)**  
 1 in. NPT x 1/2 in. NPT nipple

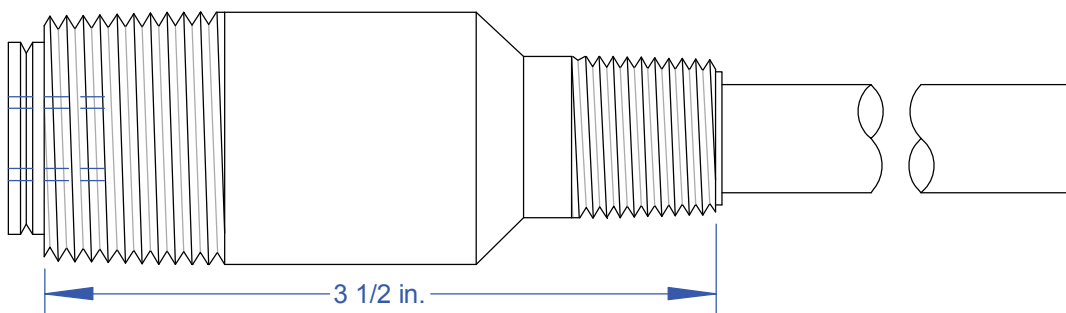

Specify as EDI Model FEz-BDG-n.n  
 where z = size code: 10, 7 or 5  
 and n.n = extension length, inches (1 in. min.)

All units are tested to 300 psi and pressure rated to 150 psi . A high pressure unit is available which has been tested to 600 psi and rated to 300 psi. The high pressure units are designated as FEH10, FEH7 or FEH5.

**Process vessel reference electrode bridge**

SCALE	FULL
DRAWN BY	FJA
DATE	17 JUL 2012
DRAWING NUMBER	FEASY-3

 **electrochemical devices, inc.**  
 PO Box 31, Albion, RI 02802 401-333-6112

www.edi-cp.com  
 info@edi-cp.com

© EDI  
 2012

Model FE-xxx-STT  
(threaded end)

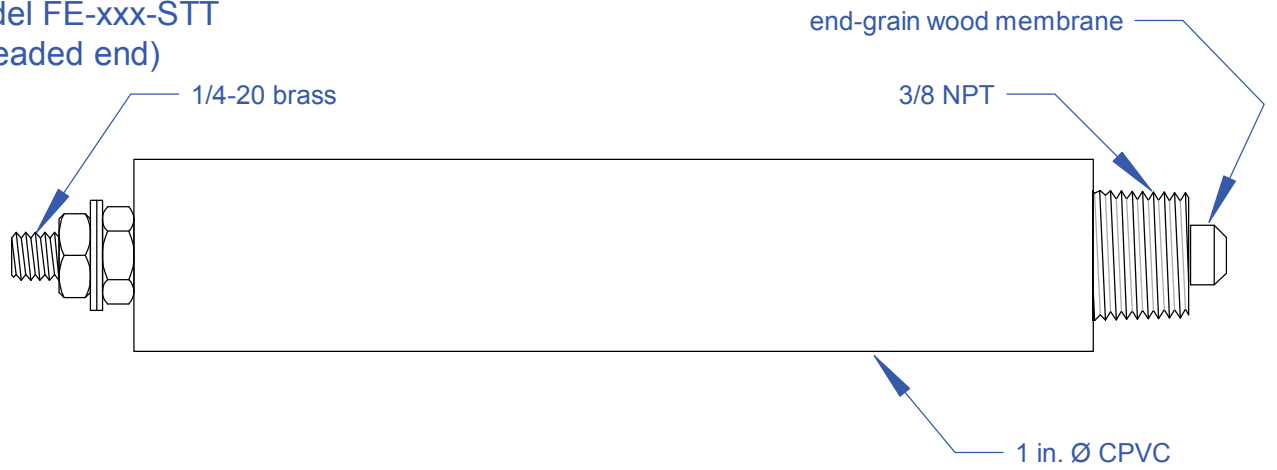

Model FE-xxx-STS  
(smooth end)

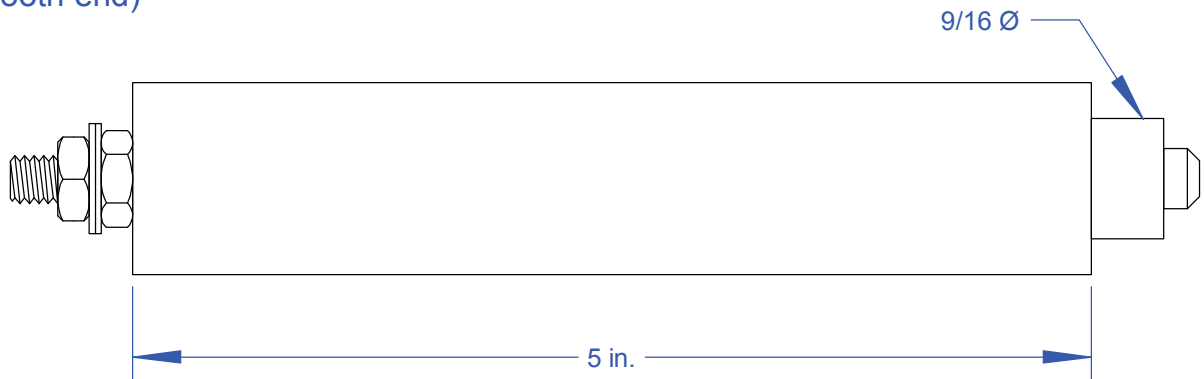

xxx in model designation is element type:  
 AGG = Ag/AgCl (saturated gelled)  
 CUG = Cu/CuSO<sub>4</sub> (saturated gelled)

## Process vessel reference electrode body

SCALE	FULL
DRAWN BY	FJA
DATE	01 JUN 2012
DRAWING NUMBER	FEASY-4

**edi** electrochemical devices, inc.  
 PO Box 31, Albion, RI 02802 401-333-6112

www.edi-cp.com  
 info@edi-cp.com

© EDI  
 2012

### Model FE10-CPN

1 in. NPT x 1 in. NPT nipple

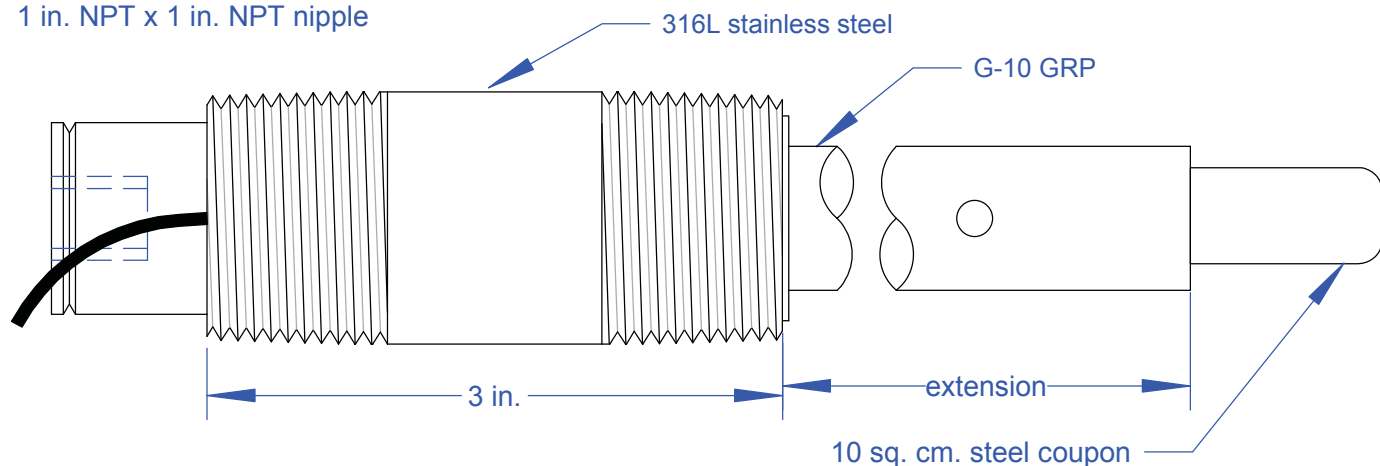

### Model FE7-CPN

1 in. NPT x 3/4 in. NPT nipple

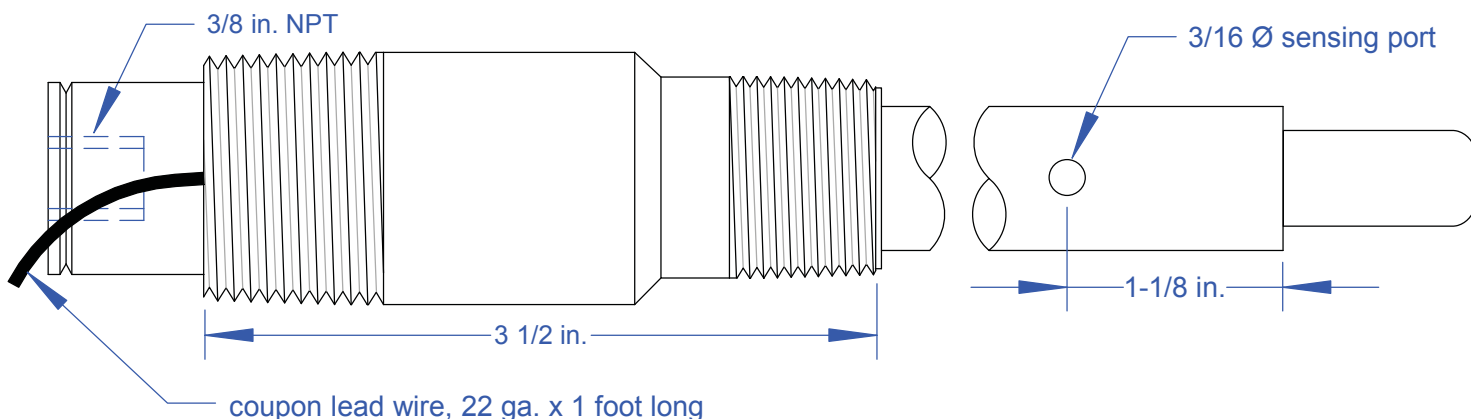

The coupon lead wire is connected to the structure through an interruptable shunt such as EDI Model UI-MS or equivalent.

Extension length is chosen so that the sensing port is located about 1 1/2 to 2 inches from the wall.

Specify as EDI Model FEz-CPN-n.n where z = size code: 10, or 7 and n.n = extension length, inches (2 1/2 in. min., 6 in. max)

All units are tested to 150 psi and pressure rated to 75 psi .

## Process vessel bridge with coupon



**electrochemical devices, inc.**  
PO Box 31, Albion, RI 02802 401-333-6112

www.edi-cp.com  
info@edi-cp.com

© EDI  
2012

SCALE	FULL
DRAWN BY	FJA
DATE	14 DEC 2012
DRAWING NUMBER	FEASY-5

# Operating Instructions

The Model FE Process Vessel reference electrode consists of two pieces:

1. A bridge, which is permanently installed on the vessel,
2. A reference, which can be either permanently installed or temporarily inserted when measurements are required.

All bridges are pressure rated to 150 psi (1,000 kPa). The bridge is designed to leak slightly in service to ensure good conductivity; the quantity of liquid emitted will be proportional to the pressure differential across the bridge.

## Temporary Electrode Installation

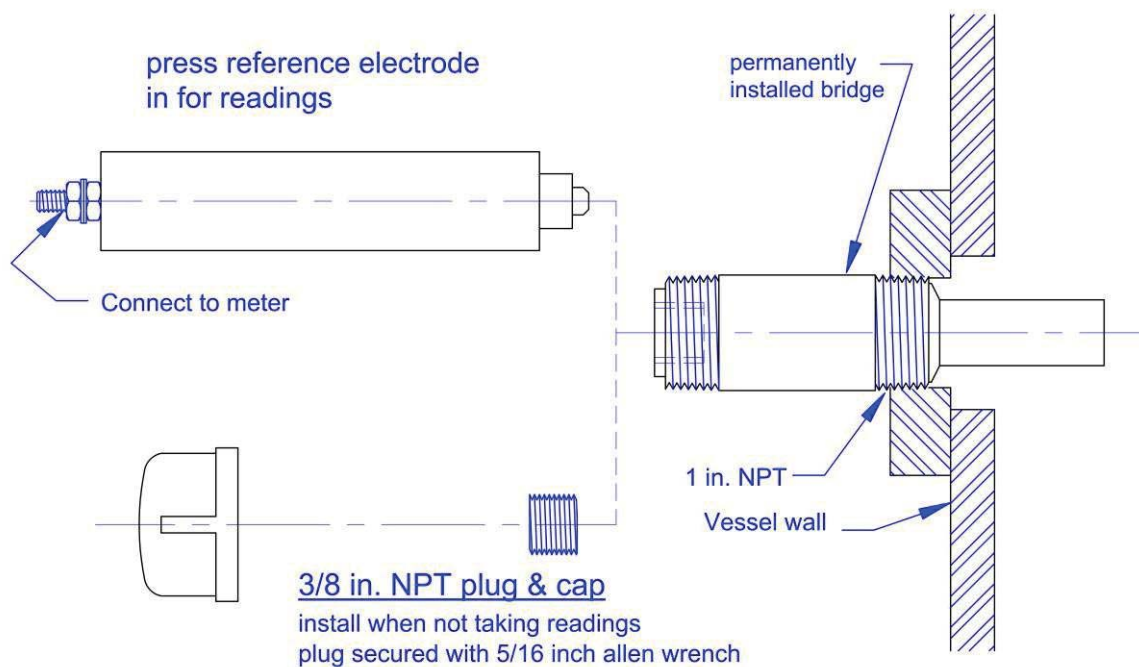

In a temporary installation, the reference electrode is inserted into the bridge whenever a potential measurement is required. If electrolyte weeping from the bridge contacts the metal nipple, the readings may be affected. This can be prevented by drying the plastic extending from the nipple before making readings. In between readings, the 3/8 inch pipe plug should be installed in the bridge; at pressures over 50 psi (350 kPa), the 1 inch end cap should also be used. Since the bridge will leak slightly, Teflon tape or a non-hardening Teflon pipe dope should be used on the end cap threads when leak-free installation is required.

***Whenever the end cap or pipe plug is removed, it should be assumed that the liquid behind it is under pressure. The cap should be slowly loosened to bleed off the pressure; once the leakage has stopped, the cap can be removed. The same procedure must be repeated when removing the plug.***

## Permanent Electrode Installation

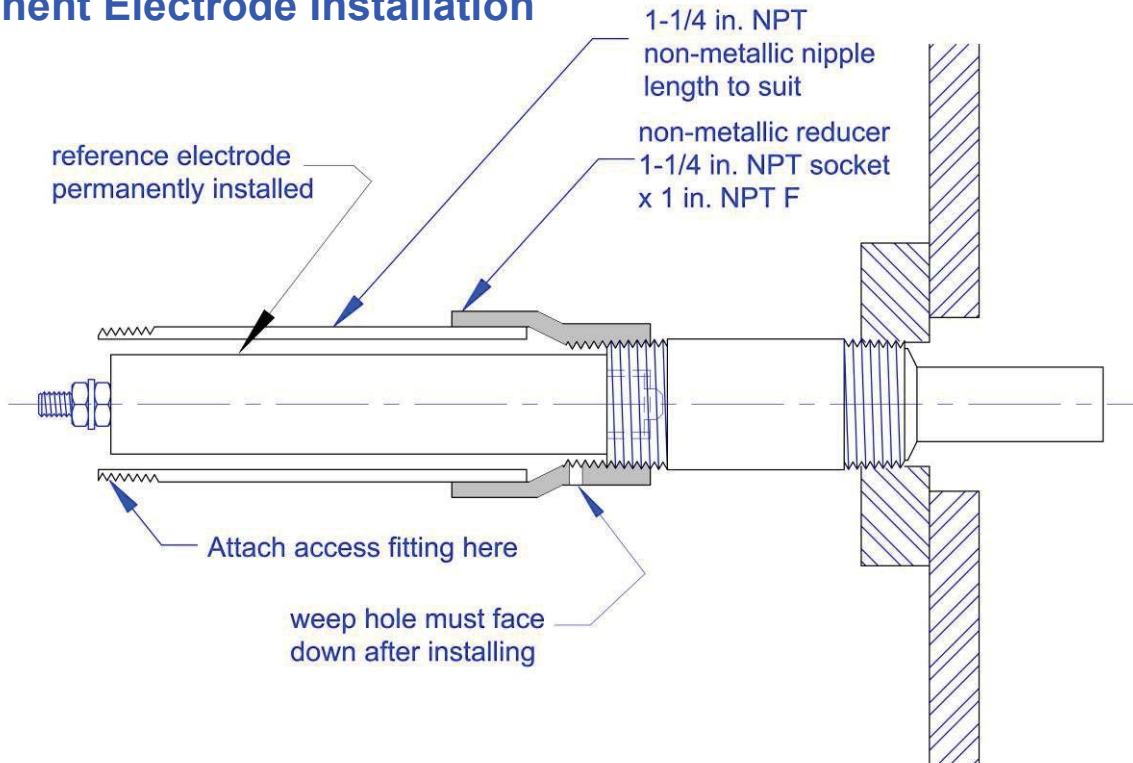

For maximum electrode life, the electrode should be installed into the bridge using no pipe thread sealants or gaskets. A small amount of liquid will leak from the joint preventing a pressure buildup between the bridge and the reference electrode. Should a leak-free joint be required, then the appropriate sealants and gasket can be used. Note, however, that if the gasket is used, the bridge will be operating at the vessel pressure, which can force some of the vessel contents into the electrode and shorten its life.

To replace a permanently installed electrode, it is not necessary to drain the vessel since the bridge remains permanently installed. Loosen the electrode just enough for the joint to start leaking which will relieve any pressure at the end of the bridge. When the leaking stops, continue to slowly unscrew the electrode until it is removed. A new electrode can then be installed.

### **Safety Precautions**

*Appropriate safety equipment as required by the vessel contents and pressure must be used whenever the pipe plug, end cap or electrode is removed from the bridge. At a minimum, suitable eye protection must be used even if the vessel only contains water. It is always possible that a small amount of liquid will spray out under pressure when the plug, cap or electrode is first loosened.*