

Slab Magnesium Anode



Applications for the use of magnesium anodes are not limited to structures buried in soil electrolytes. These anodes have also proven to be extremely effective in preventing corrosion in aqueous environments. MESA manufactures a full line of condenser anodes produced from the H-1 Alloy. The anodes produce an open circuit potential of 1.53 - 1.55 volts, and are cast into various shapes. These anodes are cast with a galvanized steel pipe core for mounting on steel studs.

Typical Applications

Condensers, Heat Exchangers, Internal tank surfaces.

Installation

- Weld stainless steel stud to structure, either on horizontal or vertical surface, with unthreaded side to structure.
- Spread gasket compound uniformly over one side of the rubber gasket and place gasket over stud with gasket compound side against structure. Gasket compound will help in holding rubber gasket in place during anode installation.
- Slip rubber tubing over stud, pushing down until tubing contacts rubber gasket. (Only required when utilizing resistor washer.)
- Slip anode over stud, making sure exposed pipe core is "up" or away from structure. Hold anode in place with hand.
- Place resistance washer over stud (either side up). Note: Color of insulator designates resistance value washer. Black=1 ohm, white=1/2 ohm, red=1/4 ohm. (Only required when utilizing resistor washer.)
- Place steel flat washer over stud, followed the 1/2" Flex-Loc Nut, and tighten as required.
- Place rubber washer and center as needed, followed by black internally threaded hex head nut protector until snug. This completes installation.

Composition								
Al	Mn	Zn	Si	Cu	Ni	Fe	Other	Magnesium
5.3 – 6.7%	0.15% min	2.5 – 3.5%	0.30% max	.010% max	0.003% max	0.003% max	0.30% max	Remainder

Item Number	Weight	Diameter	Thickness	Pipe Core Size
E1	1 lb	4 in	1 1/4 in	1/2 in
2R5	2 lb	5 in	2 in	3/4 in
E2	2 lb	4 in	2 1/2 in	1/2 in
6SX3	6 lb	3" x 4" x 8"		3/4 in
7.5S	7.5 lb	8" x 8" x 2"		3/4 in
15S	15 lb	8" x 8" x 4"		3/4 in

Slab Mounting Kit:

Anodes are normally bolted to the structure by threaded studs. Mounting kits are available consisting of the following parts (1 of each):

- 3-3/4" x 1/2" Stainless Steel Weld Stud
- 10" x 10" x 1/16" rubber gasket
- Package of Gasket Compound
- Steel Washer
- 1/2" Flex-Loc Nut
- Rubber Washer for Stud Protector
- Plastic Stud Protector

Additional parts for Resistor Mounting:

- 1 Resistance Washer (specify 1/4, 1/2, or 1 ohm)
- 2" long x 1/2" ID rubber tubing

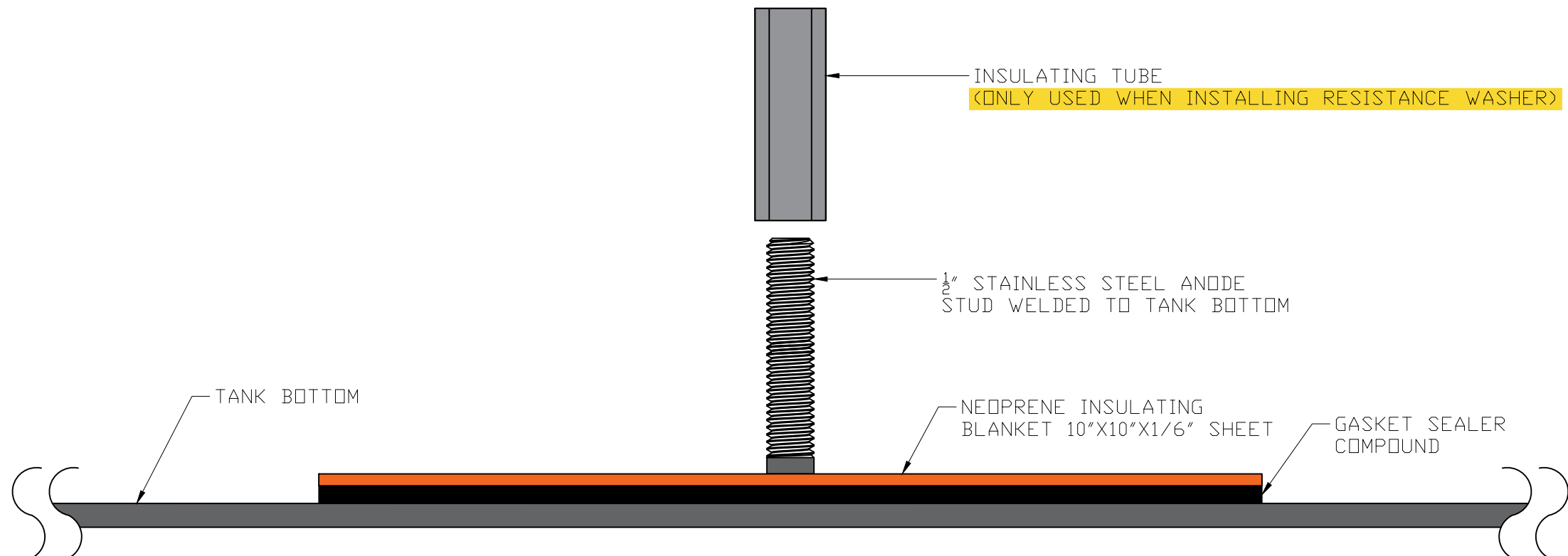
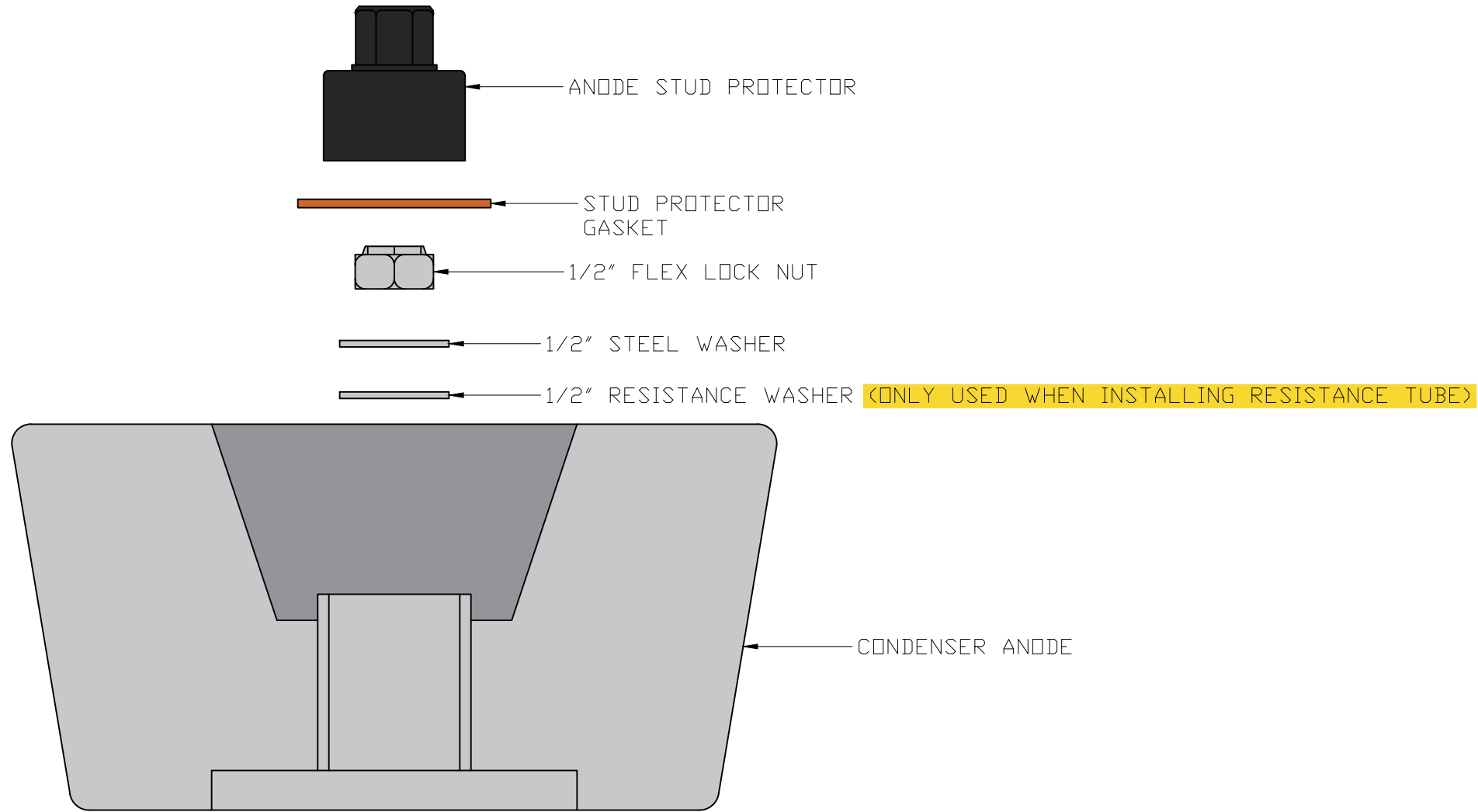

"ALL DIMENSIONS IN INCHES"
 TOLERANCE:
 (UNLESS OTHERWISE STATED)

0.XXXX	=±0.0005"
0.XXX	=±0.005"
0.XX	=±0.010"
0.X	=±0.100"

MATERIAL DESCRIPTION:
 CONDENSER/SLAB MAG MOUNTING KIT

REVISION				
REV	DESCRIPTION	DATE	BY	APP
0	APPROVED	3/10/2021	MM	PM

CLIENT NAME & ADDRESS:
 MESA



TULSA, OK | Dallas-Ft. Worth, TX | Houston, TX | Tallahassee, FL | Wapakoneta, OH
 THIS DOCUMENT AND THE INFORMATION CONTAINED HEREIN ARE THE PROPERTY OF MESA, AND HAS BEEN PRODUCED SOLELY FOR THE USE OF OUR CLIENT. THIS DRAWING IS CONFIDENTIAL AND PROPRIETARY AND SHALL NOT BE USED, DIRECTLY OR INDIRECTLY, FOR ANY REASON OTHER THAN THAT WHICH IT IS INTENDED, OR IN ANY WAY DETRIMENTAL TO OUR INTERESTS.

DESCRIPTION:
 MAGNESIUM CONDENSER ANODE KIT

JOB NO.:	SCALE: DO NOT SCALE	SHEET: 1 OF 1	
DRAWN BY: MM	DRAWN DATE: 3/9/2021	CHK'D BY: PM	CHK'D DATE: 3/10/2021
DWG NO.:	2463	REV: 0	