

Optional Features

Air Cooled Gas Station Series

- AC and/or DC lightning protection
- Communication filters
- Meter switches
- AC/DC failure light
- DC circuit breakers
- 115 VAC convenience outlet
- Alternate output control (constant current, constant voltage, constant potential)
- NRTL / ETL third party certification
- Other options per request of customer

Standard Gas Station Series

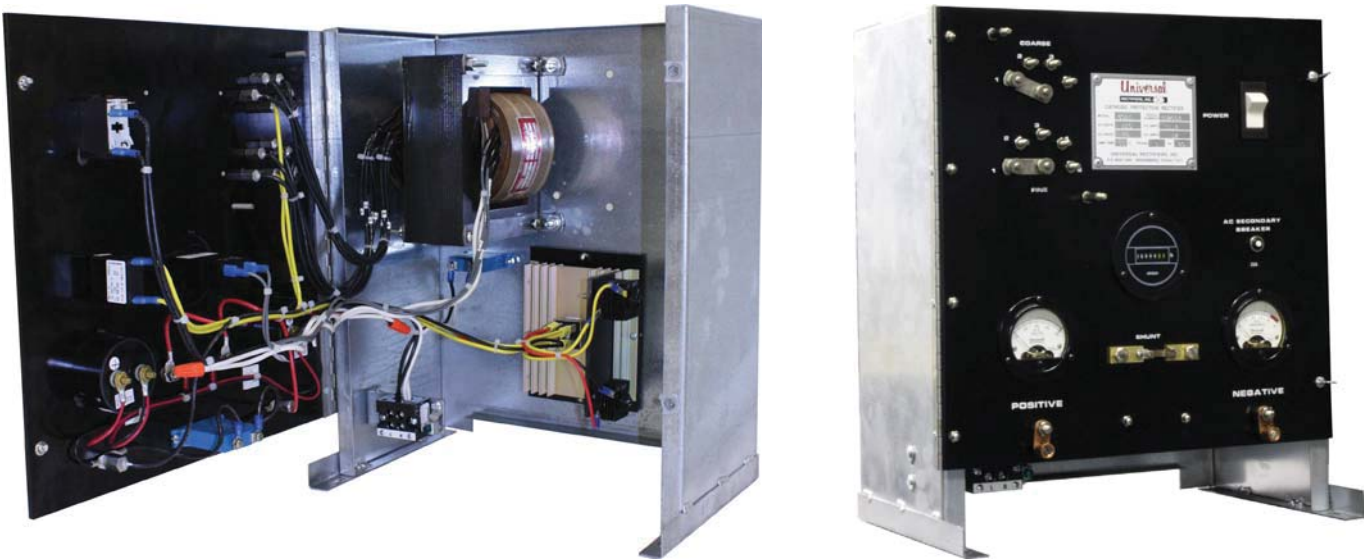

Cabinet Wattage & Weight

Case Size	Maximum DC Watts	Shipping Weight
Pro-1	1000	100 lbs
Pro-2	1500	150 lbs

Each rectifier is custom built and will vary in weight:
The weights above are approximate.

Typical Cabinet Dimensions

Air Cooled **Gas Station Series**

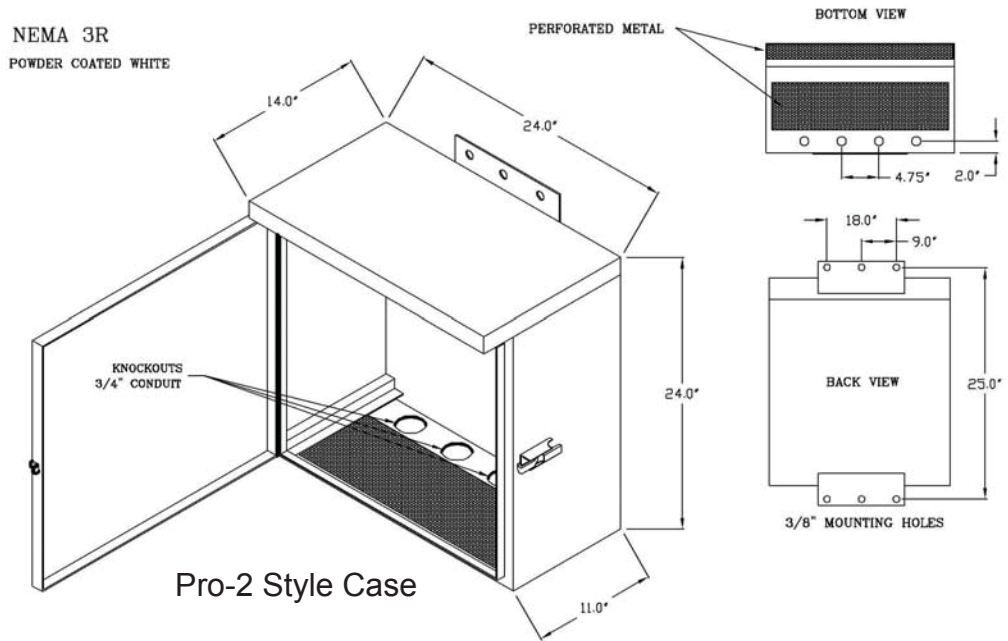
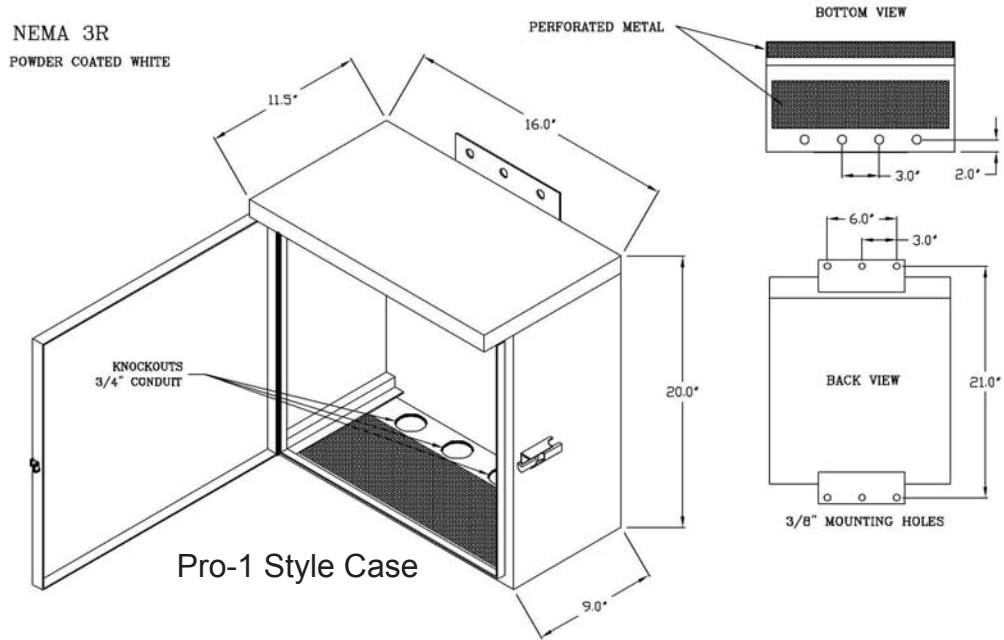

Ordering Code / Model Number

Air Cooled Gas Station Series

Position #1: Model

G = Gas Station Series

Position #2: Type

S = Standard Rectifier (Manual taps)
C = Constant Current (Reactor style)
D = Constant Current (Solid state)
E = Constant Voltage (Solid state)

P = Constant Potential (solid state)
M = Multiple Modes (solid state)
V = Variac Control

Position #3: Cooling

A = Air Cooled

Position #4: Stack Type

I = Silicon

Position #5: DC Volts

List Maximum DC Voltage Desired

Position #6: DC Amps

List Maximum DC Amperage Desired

Position #7: AC Input

G = 115, 1 phase only

Position #8: Special Features

C = AC and DC arrestors
D = DC arrestor
E = AC arrestor
G = Communications filter
H = Meter switches

J = Power On indicator light
K = DC failure warning light
M = DC breaker
R = 115 VAC convenience outlet
Q = Other, specify